

BLACKMER PARTS LIST

PUMP MODELS: TXD2.5A, TXSD2.5A (Double Ended Shaft)
TX2.5A, TXS2.5A (Single Ended Shaft)

Keep with Instructions 201-A00 for Installation, Operation and Maintenance

This doc is for TXSD2A & TXS2A discontinued Jan 2012

TXS equivalent may now be specified via a TX pump with options

Section 201
Effective Aug 2011
Replaces Sept 2009

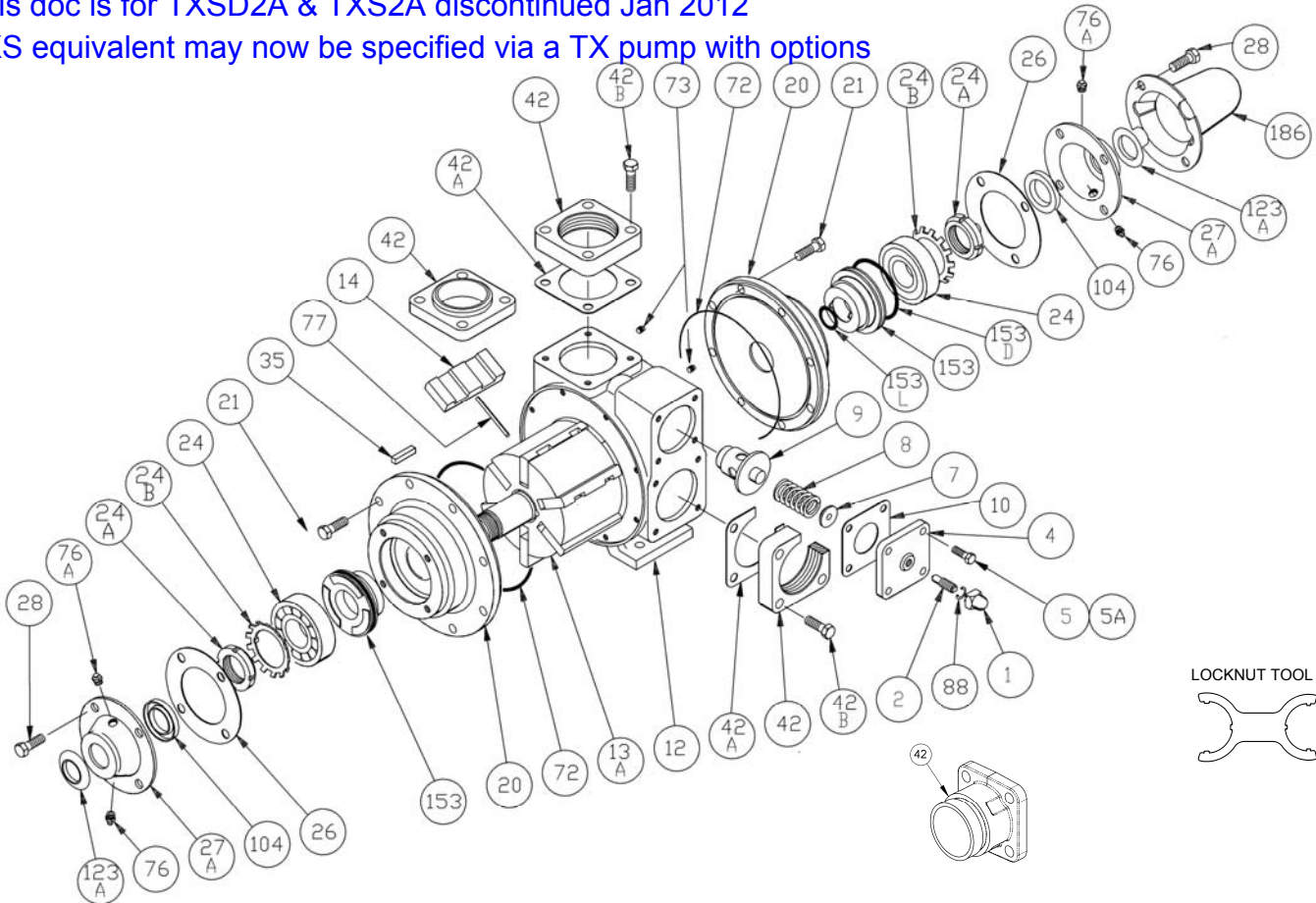

Ref. No.	Description	Parts Per Pump	Part No.	Ref. No.	Description	Parts Per Pump	Part No.
1	Cap – Relief Valve (R/V)	1	411453	28	Capscrews – Bearing Cover	8	920285
2	Adjusting Screw – R/V	1	431401	35	Key – Shaft Square	1	^{1,2} 909209
4	Cover – Relief Valve	1	411607	42	Flanges		
5	Capscrew – R/V Cover	3	920316	42A	Gasket – Flange		See Backside
5A	Capscrew w / Hole – R/V Cover	1	920310	42B	Capscrews – Flange		
7	Spring Guide – R/V	1	423955	42C	O-Ring – Victaulic Flanges		
8	Spring – R/V (51-110 psi) (Std.)	1	471631	72	O-Ring – Head (Buna-N) (Std. TXD)		¹ 701947
	Spring – R/V (111-125 psi)		471614		O-Ring – Head (FKM) (Std. TXSD)	2	701914
9	Valve – R/V (Std. TXD) ³	1	451623		O-Ring – Head (PTFE)		702242
	Valve – R/V (Nickel Plated, Std. TXSD)		451624	73	Gage Plug	2	908198
10	Gasket – R/V Cover	1	¹ 531603	76	Grease Fitting	2	317815
12	Cylinder – Pump	1	021605	76A	Grease Relief Fitting	2	701992
13A	Rotor & Shaft Assy. - Double Ended ⁴	1	261665	77	Push Rod	3	¹ 121607
	Rotor & Shaft Assy. - Single Ended ⁴		261667	88	Gasket – R/V Cap	1	¹ 701981
14	Vane – Duravane	6	¹ 091619	104	Grease Seal	2	¹ 331918
20	Head (Std.)	2	031425	123A	Dirt Shield	2	¹ 701480
21	Capscrews – Head	16	920331	186	Shaft Protector	1	341601
24	Ball Bearing	2	¹ 903156		Air Valve Kit – Piston Type (FKM)		891725
24A	Locknut – Bearing	2	903521		Air Valve Kit – Diaphragm Type		891696
24B	Lockwasher – Bearing	2	¹ 903522		Tool - Locknut		903091
26	Gasket – Bearing Cover	2	¹ 381406		Kit – Maintenance (TXD2.5A only)		898951
27A	Bearing Cover	1 - 2	041431				
	Bearing Cover – Outboard, SE shaft	0 - 1	041433				

¹ Included in Maintenance Kit

² Maintenance Kit also includes Woodruff Key 909130 used previously

³ For Piston Style Air Operated RV see IOM 201-G00, Diaphragm Air RV – 201-F00, DMX Diaphragm RV – 201B-B00.

⁴ Includes Ref. Nos. 24A & 24B

MECHANICAL SEALS - TX(S)D2.5A MODELS

REF. NO.	PART NAME	PARTS PER PUMP	PART NO.
153	Mechanical Seal Complete - Std. TXD Cast Iron Stationary Seat, Carbon Seal Face, Buna-N O-Rings. (INCN)	2	¹ 331601
	Mechanical Seal Complete - Std. TXSD Cast Iron Stationary Seat, Carbon Seal Face, FKM O-Rings. (IVCV)		331655
	Mechanical Seal Complete - Cast Iron Stationary Seat, PTFE O-Ring, Carbon Seal Face w/ PTFE Seal Ring. (IACT)		331673
153D	O-Ring - Stationary (Buna-N)	2	701934
	O-Ring - Stationary (FKM)		701921
	O-Ring - Stationary (PTFE)		702056
153L	O-Ring - Rotating (Buna-N)	2	701922
	O-Ring - Rotating (FKM)		701980
	Seal Ring - Rotating (PTFE)		**

¹ Included in Maintenance Kit

** PTFE Rotating Seal Ring is not available as a separate part.

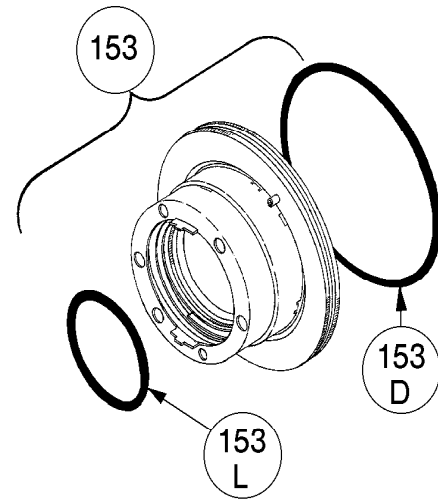

FLANGES

REF. NO.	PART NAME	PARTS PER PUMP	PART NO.
42	Flange - 2" NPT	1 - 2	651603
	Flange - 2 1/2" NPT		651611
	Flange - 2 1/2" Weld		651608
	Flange - 2" Victaulic		655116
	Flange - 2 1/2" Victaulic		655117
	Flange - 3" Victaulic		655118
42A	Gasket - Flange, NPT and Weld	0 - 2	¹ 381650
42B	Capscrews - 2" NPT Flange	4 - 8	920471
	Capscrews - 2 1/2" NPT Flange		920532
	Capscrews - 2 1/2" Weld		920491
	Capscrews - Victaulic Flanges		920491
42C	O-Ring - Victaulic Flange (Buna-N)	0 - 2	701925
	O-Ring - Victaulic Flange (FKM)		701924
	O-Ring - Victaulic Flange (PTFE)		702079

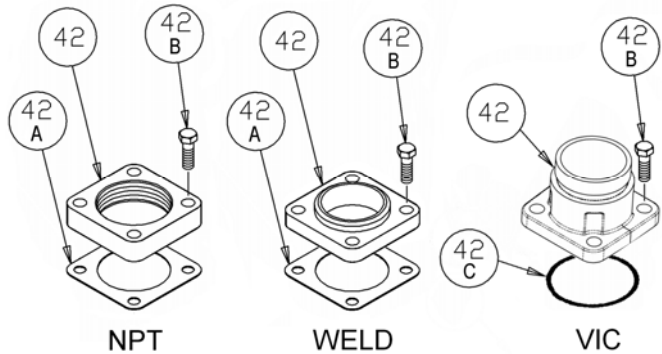

OPTIONAL HYDRAULIC MOTOR ADAPTER PARTS

REF. NO.	PART NAME	PARTS PER PUMP	PART NO. 1-1/4" Hyd Motor Shaft	PART NO. 1" Hyd Motor Shaft
	Hydraulic Motor Adapter Kit *		891458	891205
26A	Gasket - Hydraulic Motor Adapter	1	383940	383940
28A	Capscrew - Hydraulic Motor Adapter / Head	4	920369	920369
34	Coupling w/ Setscrew - for straight key hyd. motor shaft	1	906967	906966
35	Key - Coupling	1	909184	N/A
76	Grease Fitting	1	317815	317815
76A	Grease Relief Fitting	1	701992	701992
135	Hydraulic Motor Adapter - SAE A Flange	1	041828	041827
135A	Capscrew - Adapter / Motor	2	920510	920510

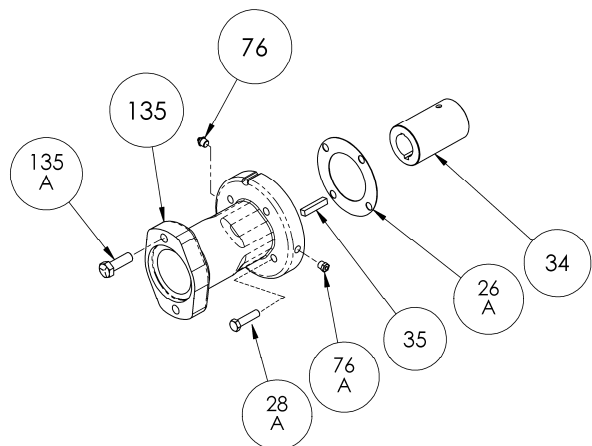

* Hydraulic Motor Adapter Kits shipped prior to Spring 2002 were of a two piece design - refer to 206-B00.



1809 Century Avenue, Grand Rapids, Michigan 49503-1530, U.S.A.

Telephone: (616) 241-1611 / Fax: (616) 241-3752

E-Mail: blackmer@blackmer.com / Internet: www.blackmer.com

Parts List 201-A03

Page 2 of 2