

# BLACKMER PARTS LIST

## With Installation and Maintenance Instructions T-TYPE TRUCK PUMP STRAINERS FOR PUMP SIZES: 2", 2.5", 3"

960326      **PARTS LIST**  
Page 1 of 2      **201-B00**

Section | 201  
Effective | Oct 2006  
Replaces | July 2001

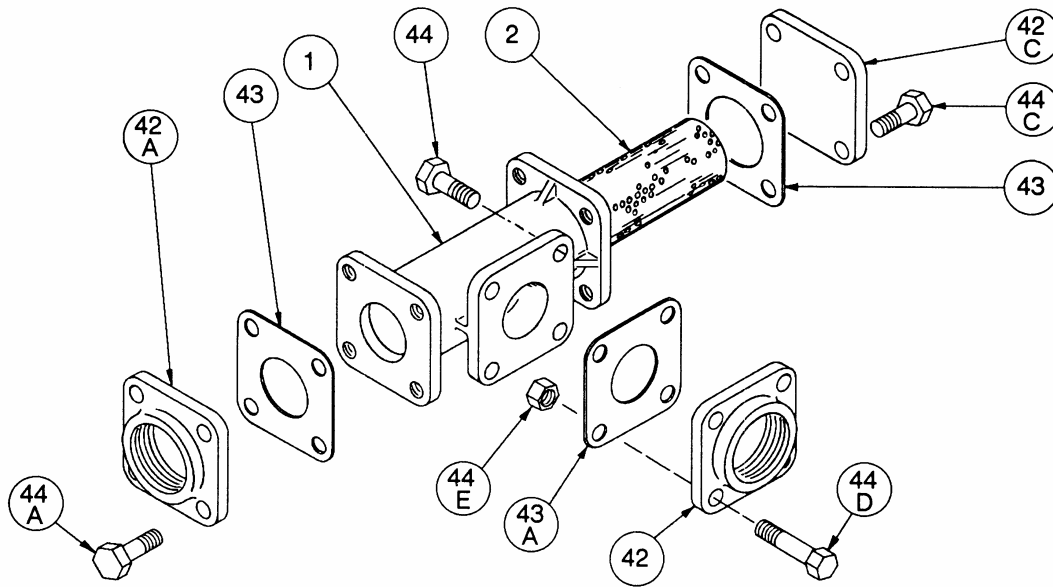

Ref. No.	Description	Qty.	Part No. 2" Size	Part No 2.5" Size	Part No 3" Size
1	Strainer Assembly	1	740053	740056	740061
2	Strainer Basket	1	621608	621612	621801
42	Body Flange - Plain <sup>2</sup>	0 - 1	651411	651611	651803
42A	Inlet Flange - Plain	1	651603	651611	651803
42C	Strainer Cover	1	611431	611633	611831
43	Gasket - Inlet Flange, Strainer Cover	2	381650	381650	381816
43A	Gasket - Body Flange	1	381421	381650	381816
44	Capscrew - Strainer Body <sup>1</sup>	0 - 4	920331	920471	920491
44A	Capscrew - 2" Inlet Flange	4	920471	920471	—
	Capscrew - 2 1/2" Inlet Flange		—	920532	—
	Capscrew - 3" Inlet Flange		—	—	920532
44C	Capscrew - Strainer Cover	4	920471	920471	920491
44D	Mounting Bolt - Body Flange <sup>2</sup>	0 - 4	920381	920547	920547
44E	Nut - Mounting Bolt <sup>2</sup>	0 - 4	922841	922850	922850

<sup>1</sup> For direct pump mounting use Ref. Nos. 43A and 44.

<sup>2</sup> For intake line mounting use Ref. Nos. 42, 43A, 44D and 44E.

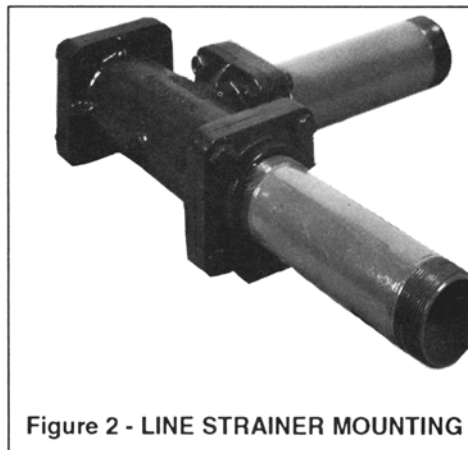
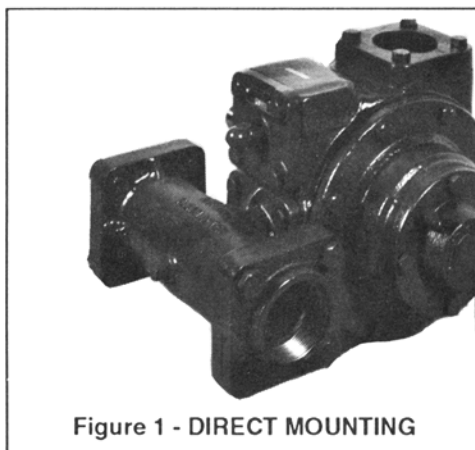

**NOTICE:**  
Blackmer manuals and parts lists may be obtained by contacting Blackmer customer service or via the Blackmer website ([www.blackmer.com](http://www.blackmer.com)).

# INSTALLATION

## NOTICE:

Blackmer truck pumps **MUST** only be installed in systems which have been designed by qualified engineering personnel. The system **MUST** conform to all applicable local and national regulations and safety standards.

These instructions are intended to assist in the installation of Blackmer T-Type strainers, and **MUST** be kept with the pump.

Blackmer truck pump service shall be performed by qualified technicians **ONLY**. Service shall conform to all applicable local and national regulations and safety standards.

Thoroughly review the pump manual, all instructions and hazard warnings, **BEFORE** performing any work on Blackmer truck pumps.

Maintain **ALL** system and Blackmer truck pump operation and hazard warning decals.

## STRAINER MOUNTING

Blackmer T-Type strainers are designed for direct mounting on Blackmer truck pumps, or as line strainers for use with Blackmer truck pumps or other makes of pumps. T-Type strainers are available in 2, 2.5 and 3-inch sizes.

For direct mounting on Blackmer 2, 2.5 and 3-inch truck pump models, the strainer takes the place of the intake pipe flange and bolts directly to the INTAKE port of the pump. To mount the strainer directly on the Blackmer pump, use four (4) strainer capscrews (Ref. No. 44) and flange gasket (Ref. No. 43A). See Figure 1.

When using the Blackmer T-Type strainer as a line strainer, 2, 2 1/2 and 3-inch NPT tapped pipe flanges are available to adapt the strainer for use in the intake line. To mount the strainer in the intake line, use the strainer body flange (Ref. No. 42), flange gasket (Ref. No. 43A), and four (4) mounting bolts and nuts (44D & 44E). See Figure 2.



Failure to set the vehicle emergency brake and chock wheels before performing service can cause severe personal injury or property damage.

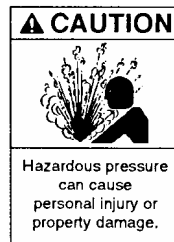

Failure to relieve system pressure prior to performing pump service or maintenance can cause personal injury or property damage.

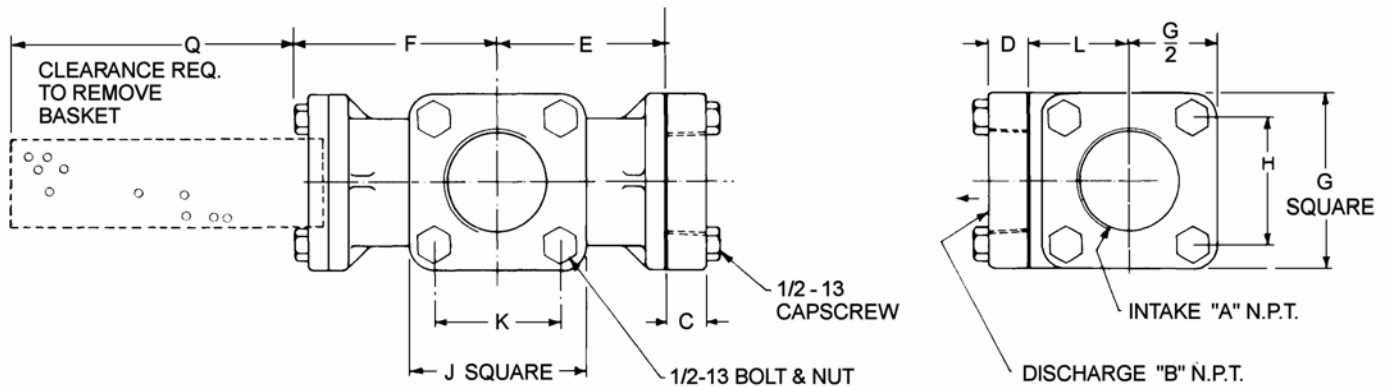

Dimensions – in. (mm)

Strainer Size	C	D	E	F	G	H	J	K	L	Q
2	1 (25.4)	3/4 (19)	3 13/16 (72.6)	4 3/4 (121)	4 (102)	2 7/8 (73)	3 5/8 (92)	2 5/8 (66.7)	2 1/4 (57.2)	6 3/8 (162)
2.5	1 1/4 (31.8)	1 1/4 (31.8)	3 13/16 (72.6)	4 3/4 (121)	4 (102)	2 7/8 (73)	4 (102)	2 7/8 (73)	3 1/16 (77.8)	6 1/2 (165)
3	1 3/16 (30.2)	1 3/16 (30.2)	4 (102)	5 (127)	4 3/4 (121)	3 1/2 (88.9)	4 3/4 (121)	3 1/2 (88.9)	3 (76.2)	7 (178)

