

# BLACKMER PARTS LIST

## With Installation and Maintenance Instructions HELICAL GEAR REDUCERS MODEL: HRA

Section 109  
Effective Apr 2010  
Replaces Oct 2007



### This is a SAFETY ALERT SYMBOL.

When you see this symbol on the product, or in the manual, look for one of the following signal words and be alert to the potential for personal injury, death or major property damage



Warns of hazards that **WILL** cause serious personal injury, death or major property damage.



Warns of hazards that **CAN** cause serious personal injury, death or major property damage.



Warns of hazards that **CAN** cause personal injury or property damage.

### NOTICE:

Indicates special instructions which are very important and must be followed.

### NOTICE:

Blackmer gear reducers **MUST** only be installed in systems, which have been designed by qualified engineering personnel. The system **MUST** conform to all applicable local and national regulations and safety standards.

These instructions are intended to assist in the installation of and maintenance of the Blackmer gear reducer, and **MUST** be kept with the reducer.

Blackmer gear reducer service shall be performed by qualified technicians **ONLY**. Service shall conform to all applicable local and national regulations and safety standards.

Thoroughly review this manual, all instructions and hazard warnings, **BEFORE** performing any work on Blackmer gear reducer.

Maintain **ALL** system and Blackmer pump and reducer operation and hazard warning decals.

### NOTICE:

**Pump manuals, parts lists and other needed literature may be obtained from the Blackmer website ([www.blackmer.com](http://www.blackmer.com)) or by contacting Blackmer Customer Service.**

### WARNING



Hazardous voltage.  
Can shock, burn or cause death.

**Failure to disconnect and lockout electrical power before attempting maintenance can cause shock, burns or death**

### WARNING



Hazardous machinery can cause serious personal injury

**Operation without guards in place can cause serious personal injury, property damage, or death.**

### WARNING



Hazardous pressure can cause personal injury or property damage

**Disconnecting fluid or pressure containment components during pump operation can cause serious personal injury, death or major property damage**

### WARNING



Hazardous machinery can cause serious personal injury.

**Failure to disconnect and lockout electrical power or engine drive before attempting maintenance can cause severe personal injury or death.**

### WARNING



Hazardous pressure can cause severe personal injury or property damage

**Failure to relieve system pressure prior to performing pump service or maintenance can cause severe personal injury or property damage.**

### CAUTION



Extreme heat can cause injury or property damage.

**Failure to allow gear reducer to cool before attempting maintenance can cause serious personal injury.**

NOTE: Numbers in parentheses following individual parts indicate reference numbers on the Parts Lists.

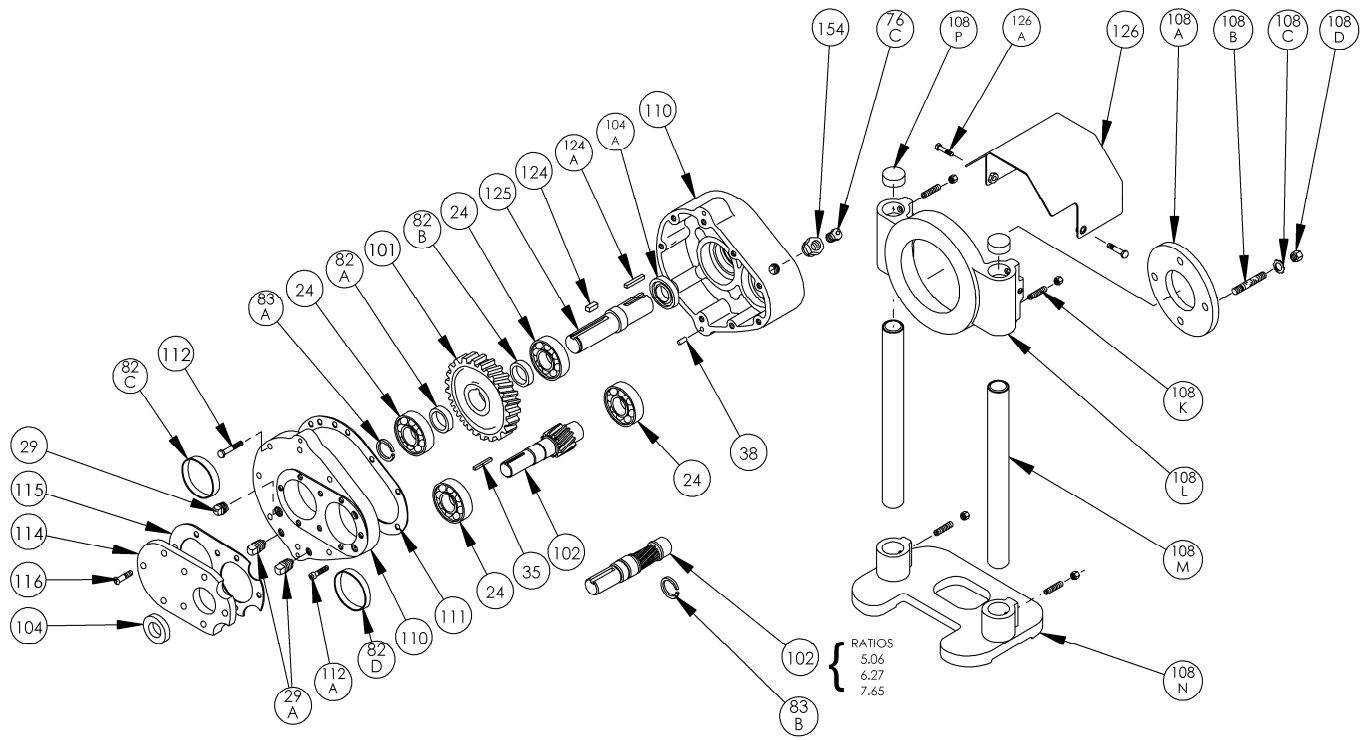

Ref. No.	Description	Parts per Unit	Part No.	Ref. No.	Description	Parts per Unit	Part No.
24	Bearing	4	903150	114	Closure Plate	1	*
29	Oil Level Plug	1	908185	115	Gasket – Closure Plate	1	814002
29A	Drain Plug	2	908100	116	Capscrews – Closure Plate	8	922754
35	Key – Pinion	1	909177	124	Key – Gear	1	909175
38	Dowel Pin	2	930739	124A	Key – Shaft	1	909183
76C	Fill & Vent Plug	1	701988	125	Shaft	1	704011
82A	Spacer Ring	1	See Table	126	Shaft Guard	1	804154
82B	Spacer Ring	1	See Table	126A	Capscrews-Shaft Guard	2	920090
82C	Spacer Ring	1	See Table	154	Bushing	1	908794
82D	Spacer Ring	0-1	See Table	—	<b>BRACKET ASSEMBLY</b>	—	871087
83A	Retaining Ring	1	See Table	108A	Bracket Ring	1	834004
83B	Retaining Ring	0-1	See Table	108B	Bracket Stud	4	921452
101	Gear	1	See Table	108C	Lockwasher	4	909625
102	Pinion & Shaft	1	See Table	108D	Nut (3/8 - 24)	10	922843
104	Oil Seal	1	331910	108K	Setscrew	6	922204
104A	Oil Seal	1	331923	108L	Mounting Bracket	1	834033
110	Gearbox Assembly <sup>1</sup>	1	894001	108M	Slider Post	2	834034
111	Gasket – Cover	1	814000	108N	Foot	1	834032
112	Capscrews – Cover (Hex Head)	7	920235	108P	Pipe Cap	2	344000
112A	Capscrews – Cover (Socket Head)	2	920233				

\*Non-saleable item – included with Gearbox Assembly. <sup>1</sup>Gearbox Assembly includes Ref. Nos. 38, 110, 111, 112, 112A, 114, 115, 116.

**GEAR AND PINION SELECTION TABLE** (Speed is based on 1750 rpm input.)

RATIO	RPM	102 PINION				101 GEAR				SPACERS				RETAINING RINGS			
		NO.	QTY.	NO.	QTY.	82A	QTY.	82B	QTY.	82C	QTY.	82D	QTY.	83A	QTY.	83B	QTY.
2.24	780	915131	1	919931	1	374002	1	374002	1	374003	1	374003	1	903618	1	NONE	-
2.76	640	915125	1	919928	1	374002	1	374002	1	374003	1	374003	1	903618	1	NONE	-
3.40	520	915126	1	919929	1	374002	1	374002	1	374003	1	374003	1	903618	1	NONE	-
4.19	420	915127	1	919930	1	374002	1	374002	1	374003	1	374003	1	903618	1	NONE	-
5.06	350	915132	1	919932	1	374001	1	374004	1	374003	1	NONE	-	903618	1	903618	1
6.27	280	915133	1	919933	1	374001	1	374004	1	374003	1	NONE	-	903618	1	903618	1
7.65	230	915122	1	919922	1	374001	1	374004	1	374003	1	NONE	-	903618	1	903618	1

# INSTALLATION

## NOTICE

This product must only be installed in systems which have been designed by those qualified to engineer such systems. The system must be in accordance with all applicable regulations and safety codes and warn of any hazards unique to the particular system.

## ALIGNMENT ADJUSTMENT

The gear reducer can be moved vertically on its bracket mount to raise or lower the output shaft (slow speed shaft) to align with the pump shaft.

The reducer can also be rotated on the bracket ring to facilitate both horizontal and vertical alignment of the input shaft (high speed shaft) to the motor shaft. This flexibility in movement eliminates the need for shims under the motor or driver in most cases. NOTE: Refer to Blackmer Dimensions 109-102 for maximum variation of shaft alignment to maintain proper gear reducer lubrication.

Follow these steps to align the reducer:

1. Align the output shaft to the pump shaft by loosening the four (4) setscrews (108K) and locknuts in the mounting bracket (108L), enabling the reducer to slide freely on the slider posts.
2. Once the proper alignment is determined, retighten the setscrews and locknuts.
3. Align the input shaft to the motor shaft by loosening the four (4) bracket nuts (108D) in the bracket ring (108A) enabling the reducer to rotate freely. If the reducer sticks on the mounting bracket, tap it lightly with a mallet.

4. After obtaining the correct alignment, retighten the bracket nuts.

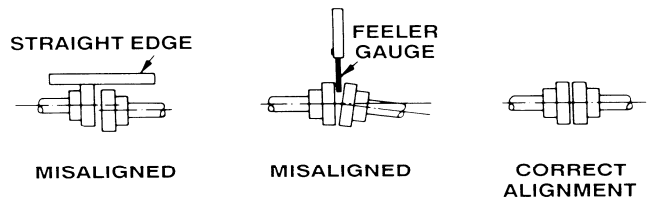

Figure 1 - Alignment Check

## COUPLING ALIGNMENT

Both angular and parallel coupling alignment MUST be maintained between the pump, gear, motor, etc. in accordance with manufacturer's instructions. Verify coupling alignment after installation of new or rebuilt pumps. See fig. 1.

1. Parallel alignment: The use of a laser alignment tool or dial indicator is preferred. If a laser alignment tool or dial indicator is not available, use a straightedge. Turn both shafts by hand, checking the reading through one complete revolution. Maximum offset must be less than .005" (125 microns).
2. Angular alignment: Insert a feeler gauge between the coupling halves. Check the spacing at 90° increments around the coupling (four check points). Maximum variation must not exceed .005" (125 microns). Some laser alignment tools will check angular alignment as well.
3. Replace the coupling guards after setting alignment.

# MAINTENANCE

## NOTICE:

Maintenance and troubleshooting must be done by an individual experienced with pump and reducer maintenance and the type of system involved.

## NOTICE:

To avoid possible entanglement in moving parts do not lubricate pump bearings, gear reducer or any other parts while the pump is running.

**CAUTION:** The normal full load operating temperature of the gearcase is 180°F (82°C) – too hot to touch with the bare hand.

## LUBRICATION

**Gear reducers are not lubricated at the factory. Oil MUST be added before starting the pump.**

Horsepower calculations for Blackmer reducers are based on 75°F (24°C) ambient air temperature; 200°F (93°C) maximum oil temperature using synthetic oil.

Blackmer recommends using synthetic oil with oxidation inhibitors and is compatible with Buna elastomers. Use synthetic oil AGMA Viscosity Grade 4 or ISO Viscosity Grade 150 such as Mobil SHC 629, Shell Omala S4 GX 150, Castrol Isolube EP 150 or equivalent.

### To add oil to the gear reducer:

1. Remove the oil level plug (29) and the fill and vent plug (76C). **NOTE:** The vent fitting in the fill plug (76C) should be kept clean to prevent expansion from forcing oil leaks at the shaft.

2. Add oil through the filler hole until oil runs out of the oil level hole – approximately 0.75 qt. (0.71 l) depending on the orientation of the reducer mounting.
3. Replace the oil level plug and the fill and vent plug.
4. After the first two weeks of operation, the oil should be drained, the gearcase flushed, and new oil added.

For normal operation, the oil should be changed every six months or 1000 hours, whichever is shorter. If operation is accompanied by frequent and wide changes in temperature, or if the unit operates in an unusually moist or dusty atmosphere, the oil should be changed every 500 hours or every three months. **NOTE:** To maintain proper gear reducer lubrication, refer to Blackmer Dimensions 109-102 for maximum variation of shaft alignment.

## REDUCER DISASSEMBLY

The gearcase on the bracket mounted gear reducer can usually be removed from its bracket without disturbing the motor or pump mounting.

1. Take apart the couplings and remove the four bracket nuts (108D) and lockwashers (108C) from the bracket ring.
2. Once the bracket nuts are removed, rotate the gearcase on the bracket and swing the input shaft away from the motor.
3. The gear reducer can then be lifted off the pump with the bracket ring and studs still intact.
4. Remove the seven hex-head cover capscrews (112), and the two socket-head cover capscrews (112A). **NOTE:** The gearcase cover is located on the gearcase with two (2) dowel pins (38). These pins remain in the gearcase.

5. After the capscrews have been removed, insert a wedge between the projecting lugs on the gearcase cover and tap lightly until the cover loosens and can be removed from the casing.
6. Remove the cover gasket (111).
7. The pinion & shaft (input shaft)(102) is a one-piece assembly and does not come apart. If necessary, the bearings (24) can be removed from the shaft with the use of a bearing puller or arbor press.
8. To remove the gear (101) and bearings (24) from the output shaft (125), use a gear puller or arbor press. Support the assembly on the gear and press the shaft out of the gear and bearings.
- d. Align the gear key (124) with the notch in the gear, and press the gear (101) squarely onto the shaft. Install the spacer ring (82A).
- e. Press the second bearing onto the shaft and add a retaining ring (83A).
2. To assemble the input shaft (102) (Pinion & Shaft) a bearing must be pressed onto each end of the shaft.
  - a. Prior to installing the bearings, follow steps 1a and 1b.
  - b. For gear ratios 5.06, 6.27, and 7.65, a retaining ring (83B) must be installed ahead of the bearing on the non-driven (shorter) end of the pinion & shaft.
3. After the shafts, gears and bearings have been assembled, apply a light film of oil in the bearing bores of the gearcase to help the bearings slide into position.
4. If the oil seal (104A) has been removed from the gearcase, it must be replaced prior to reassembly. Refer to step 2 of "Oil Seal Replacement."
5. To install the shaft assemblies into the gearcase it is easiest to tip the gearcase so that it is resting on the bracket studs with the cavity opening upward.
  - a. Start the output shaft (125) into the bearing bore of the gearcase.
  - b. Align the bearings and gear teeth of the input shaft (102) with the output shaft and drop the two shaft assemblies together into their respective bearing bores. **NOTE:** It is important to line the bearings up squarely with the bores in order for them to drop smoothly into place. If the bearings are positioned correctly in the gearcase, the shafts should rotate freely when turned by hand.

## OIL SEAL REPLACEMENT

1. To replace the oil seal (104) on the **input shaft**, it is only necessary to remove the closure plate (114). Once the plate is removed, the old seal can be pressed out and a new one installed. Grease the lip of the oil seal before installing. The oil seal must be inserted such that the lip of the seal will face inward when the closure plate is reattached to the gearcase cover.
2. To replace the oil seal (104A) on the **output shaft**, it is necessary to disassemble the body and cover assembly and remove the output shaft. (Refer to "Reducer Disassembly.") Grease the lip of the oil seal and insert it into the bearing bore of the gearcase so that the lip of the seal faces inward.

## REDUCER ASSEMBLY

Before reassembling the gear reducer, clean each part thoroughly. Wash out the bearing bores and remove all burrs or sharp corners with a file.

**NOTE:** Disregard steps 1 and 2 if the shaft and bearing assemblies have not been dismantled.

1. The output shaft (125) is reduced in diameter at one end of the gear area to facilitate bearing and gear location.
  - a. Before installing the gear and bearings, remove all dirt, burrs, or sharp corners from the shaft to prevent galling or seizing of the gear and shaft.
  - b. Apply a coat of graphite, molysulphide, or white lead to the shaft.
  - c. Press the shaft squarely into the bearing (24) and install the spacer ring (82B).
6. Once the input and output shaft assemblies are properly installed, set the cover gasket (111) on the gearcase.
7. Install the spacer ring (82C) into the output bearing bore of the cover. When applicable (refer to "Gear and Pinion Selection Table"), install a spacer ring (82D) into the input bearing bore of the cover.
8. Position the cover on the gearcase using the dowel pins for alignment.
9. Install and tighten the cover capscrews (112 & 112A).
10. Make sure the oil seal (104) is inserted in the closure plate (114) before reattaching the plate to the gearcase cover. Refer to step 1 of "Oil Seal Replacement."
11. Attach the closure plate gasket (115) and the closure plate (114) to the gearcase cover.

## TROUBLESHOOTING

### NOISE AND VIBRATION

#### POSSIBLE CAUSES:

1. Worn or damaged bearings.
2. Inadequate lubrication / use of wrong lubricant.
3. Impurities in the lubricant, such as abrasive particles.
4. Excessive overloading.
5. Misalignment to either pump or motor.

#### REMEDY:

- Replace bearings.
- Check oil condition. The lubricant may not be getting to the contact areas of the gear teeth, or the viscosity of the oil may be too low for the operating temperature (see "Lubrication").
- Replace with clean oil (see "Lubrication")
- Overloading causes overheating which may lower oil viscosity and thus cause the oil film on gear teeth contact surfaces to break down. The gears will begin to "groan" as the oil loses its effectiveness. If the loading is not decreased, the gear teeth will begin to "bite" into each other and wear out rapidly.
- Recheck alignment and adjust as necessary.

